

* PATENT PENDING

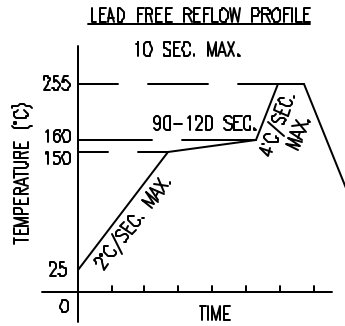

TOTAL TIME ABOVE 220°C IS 60 SECONDS MAX.

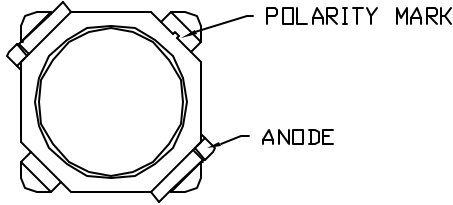
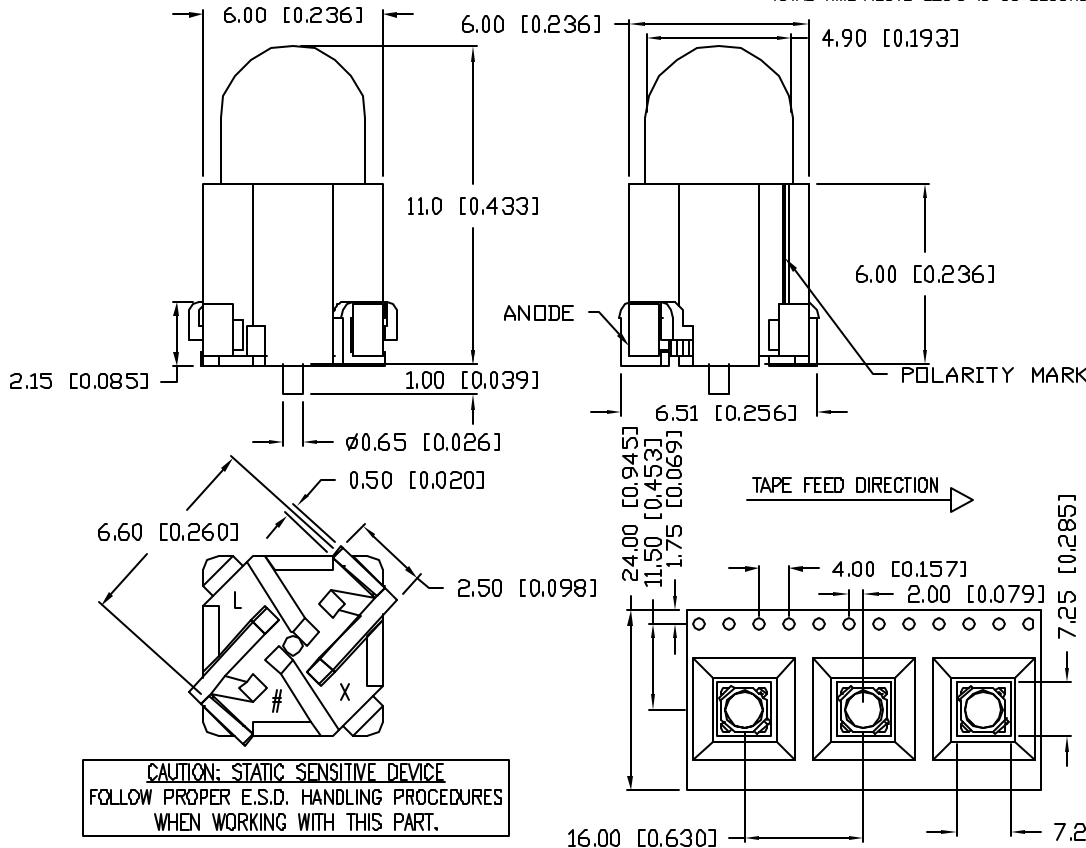

CAUTION: STATIC SENSITIVE DEVICE
FOLLOW PROPER E.S.D. HANDLING PROCEDURES
WHEN WORKING WITH THIS PART.

| | |
|------------------|------|
| PART NUMBER | REV. |
| SML-H1505UPGC-TR | |

| ELECTRO-OPTICAL CHARACTERISTICS $T_A=25^\circ\text{C}$ | | $I_f=20\text{mA}$ | | | |
|--|-------------|-------------------|-----|------------|----------------------|
| PARAMETER | MIN | TYP | MAX | UNITS | TEST COND |
| PEAK WAVELENGTH | | 520 | | nm | |
| FORWARD VOLTAGE | | 3.3 | 4.0 | V_f | |
| REVERSE VOLTAGE | 5.0 | | | V_r | $I_f=100\mu\text{A}$ |
| AXIAL INTENSITY | | 7000 | | mcad | $I_f=20\text{mA}$ |
| VIEWING ANGLE | | 45 | | $2x$ theta | |
| EMITTED COLOR: | GREEN | | | | |
| EPOXY LENS FINISH: | WATER CLEAR | | | | |

| LIMITS OF SAFE OPERATION AT 25°C PER DIE | | |
|--|-------------|------------|
| PARAMETER | MAX | UNITS |
| PEAK FORWARD CURRENT* | 100 | mA |
| STEADY CURRENT | 20 | mA |
| POWER DISSIPATION | 80 | mW |
| DERATE FROM 25°C | -1.2 | mW/°C |
| OPERATING TEMP. | -30 TO +80 | °C |
| STORAGE TEMP. | -40 TO +100 | °C |
| SOLDERING TEMP. | +260 | °C |
| 2.0mm FROM BODY | | 5 SEC. MAX |
| * $T < 10\mu\text{s}$ | | |

NOTE:
1. CATHODE IS ORIENTED TOWARDS
THE TAPE SPROCKET HOLES.

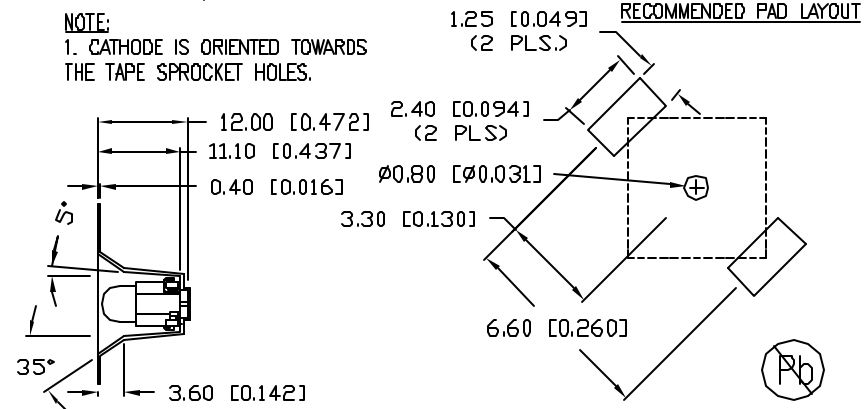

*UNLESS OTHERWISE SPECIFIED TOLERANCES PER DECIMAL PRECISION ARE: X=±1 (±0.039), XX=±0.5 (±0.020), XXX=±0.25 (±0.010), XXXX=±0.127 (±0.005), LEAD SIZE=±0.05 (±0.002), LEAD LENGTH=±0.75 (±0.030), MIN.=+DECIMAL PRECISION -0.00, MAX.=+0.00 -DECIMAL PRECISION

| | |
|---|------------------|
| REV. | PART NUMBER |
| | SML-H1505UPGC-TR |
| 5mm SURFACE MOUNTED DOME LED, 525nm ULTRA PURE GREEN LED, WATER CLEAR. | |

CONFIDENTIAL INFORMATION
THE INFORMATION CONTAINED IN THIS DOCUMENT IS THE PROPERTY OF LUMEX INC. EXCEPT AS SPECIFICALLY AUTHORIZED IN WRITING BY LUMEX INC., THE HOLDER OF THIS DOCUMENT SHALL KEEP ALL INFORMATION CONTAINED HEREIN CONFIDENTIAL AND SHALL PROTECT SAME IN WHOLE OR IN PART FROM DISCLOSURE AND DISSEMINATION TO ALL THIRD PARTIES.

RELIABILITY NOTE
OUR MANY YEARS OF EXPERIENCE DATA ACCUMULATION INDICATE THAT SOLDER HEAT IS A MAJOR CAUSE OF EARLY AND FUTURE FAILURE. PLEASE PAY ATTENTION TO YOUR SOLDERING PROCESS.

| | | |
|--|-------------|---|
| LUMEX The World's Alternative In World For You | | 290 E. HELEN ROAD PALATINE, IL 60067-6976 PHONE: +1.847.359.2790 US WEB: www.lumex.com TW WEB: www.lumex.com.tw |
| DRAWN BY: JIN | CHECKED BY: | APPROVED BY: |
| | | DATE: 03.31.08 PAGE: 1 OF 1 SCALE: N/A |